

NOTES:

SPECIFICATION:

1. CURRENT RATING: 3.0A MAX
2. VOLTAGE: 100 VAC
3. TEMPERATURE RANGE: -30 °C ~ 85 °C
4. CONTACT RESISTANCE: 40 MILLIONHM MAX
5. INSULATION RESISTANCE: 100 MEGOHMS MIN.
6. LNSERTION FORCE : 5N~20N
7. UNMATING FORCE: 8N~20N
8. DURABILITY: 10,000 CYCLES

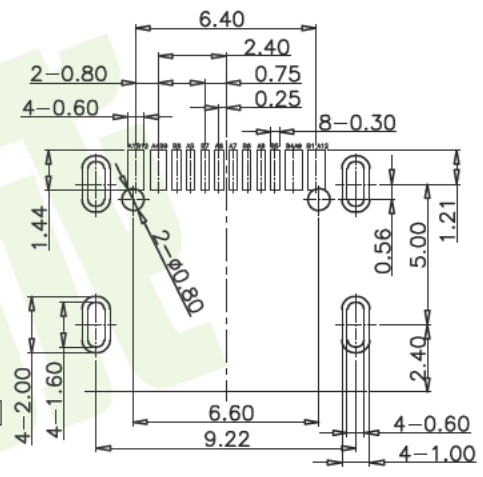
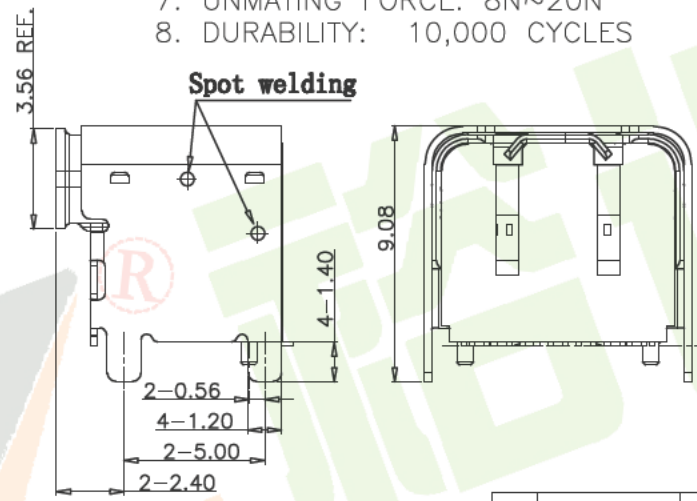
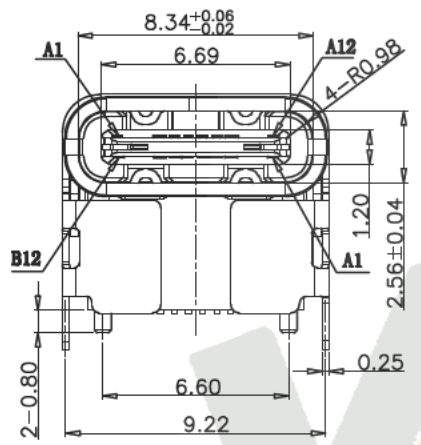

RECOMMENDED P.C.B. LAYOUT
TOLERANCE UNSPECIFIED ±0.05mm

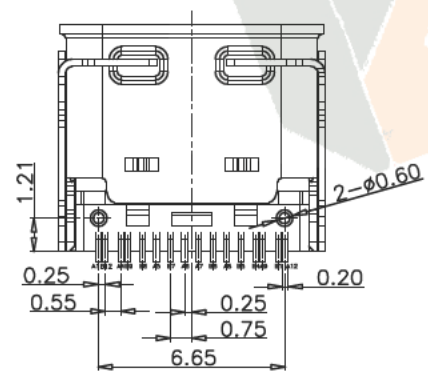

7	UPPER SHELL	SUS 304 T=0.25	NI Plated	1PCS
6	SHELL	SUS 304 T=0.30	NI Plated	1PCS
5	SHIELDING PLATE	SUS 301 T=0.20	---	1PCS
4	MD	LCP S475	BLACK	1PCS
3	CONTACT	C18140	Au/Ni Plated	1SET
2	CONTACT	C18140	Au/Ni Plated	1SET
1	HOUSING	LCP S475	BLACK	1PCS
NO.	DESCRIPTION	MATERIAL	REMARKS	QTY

A1	GND	B12	GND
A4	VBUS	B9	VBUS
A5	CC1	B8	SBU2
A6	DP1	B7	DN2
A7	DN1	B6	DP2
A8	SBU1	B5	CC2
A9	VBUS	B4	VBUS
A12	GND	B1	GND
PIN	SIGNAL NAME	PIN	SIGNAL NAME

TOLERANCE		NAME(INTENDED USE) CUSTOMER DRAWING	深圳市裕诚电子有限公司
X.X ±0.30	.X' ± 2'	2016.2.5	
.XX ±0.20	.X' ± 1'	TITLE: USB C F TYPE单排SMT插高4.3 CONN	
.XXX ±0.10	.XX' ±0.5'	APPD: DMX 陈雅	DRAWG NO. TYPE-C-DG43
UNITS	mm	DRAWN: TANG 洪章波	
MATERILA		DRAW: SHI 魏杰	
FINISH		SCALE	SHEET
		1:1	1/1
		REV.	A