

TER	ANG.	0° (▨=NO)			
		(20°)	(15°)	(15°)	(20°)
①		▨			
②					▨
③		▨	▨		▨

CCW ← → CW

CODE TABLE



Circuit Diagram

NOTE:

Operating Force:

lever portion 100 ± 30 gf

Push portion 205 ± 50 gf

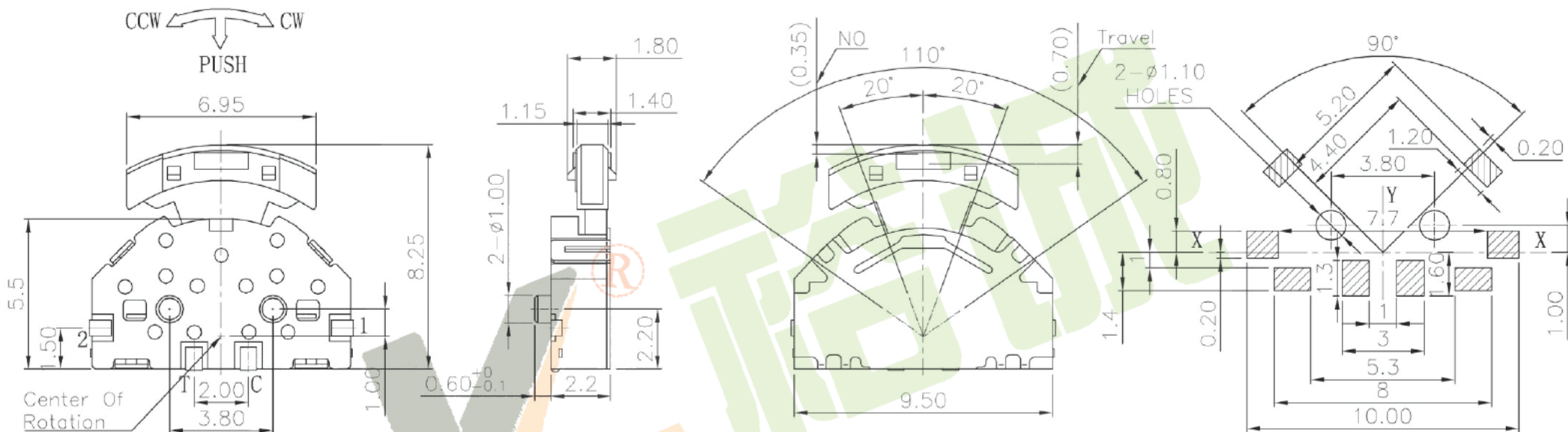

P.C.B Mounting Pattern Dimension

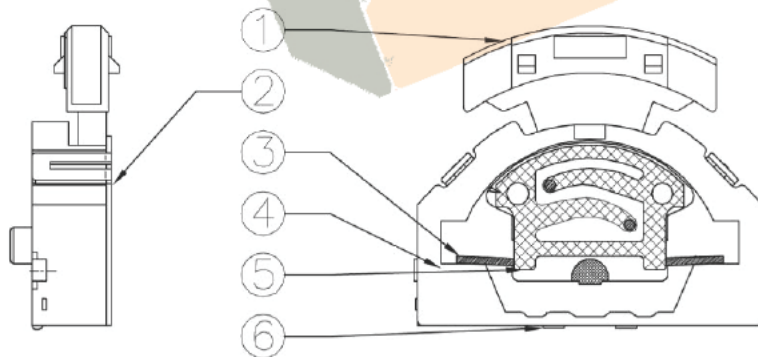

⑥	Contact	—	1	F.Ag/Brass	—	—
⑤	Terminal	—	4	Brass(0.15t)	Plating silver	—
④	Base	—	1	Nylon	Black	—
③	Spring	—	1	SUS	—	—
②	Cover	—	1	SUS	White	—
①	Keystoke	—	1	Nylon	Black	—
ITEM	PART NAME	TER'NO.	QTY.	MATERIAL	FINISHING	REMARK

APPROVALS

DATE

DRAWN

J.X.Zhang

2013/8/15

深圳市裕诚电子有限公司  
SHENZHEN YUCHENG ELECTRONICS CO.,LTD

CHECKED

WEBSITE

www.ycelectron.com

APPROVALS

PART NO.

M1-5226G

TOLERANCES ARE

30~以下 ±0.30  
10~30 ±0.20  
5~10 ±0.15  
~ 5 ±0.10

ANGLE

UNIT: mm

SCALE: 1:1

PROJ:

DRAWING NO.

SHEET 1 OF 1

ECN NO.	REV.	DATE.	DESCRIPTION.	CHANGE.	CHECK.	APPRO.
—	A	—	NEW	—	—	—